

The **isocheck** Deep Batten System (for Timber Frame)

LAYING & FIXING INSTRUCTIONS

SITE CONDITIONS

Before installation of **isocheck** Batten it is essential that all site conditions are as specified. Installation should not commence until these conditions are met.

Sub Floor

The sub-floor is to be swept free of any loose debris leaving a smooth surface on which to place the **isocheck** Batten. The building must be weatherproof and completely dried out before commencing installation of the flooring system. It is most important for the reduction of airborne sound to block any air passage in the structural floor, at the perimeter of the floor and wherever the floor is penetrated. Any flooring components exposed to wet conditions such as rain or plumbing leaks should be replaced.

Services

The location of services should be detailed at an early stage. Services should be kept at least 150mm away from walls to allow space for perimeter bearers.

Ceramic Tiles

Risks can be significantly reduced by good detailing and the use of modern flexible adhesives. When laying ceramic tiles on floating floors please contact us for specialist advice.

Storage

All components should be kept inside, under cover and in dry conditions at all times. Materials should be located in the area in which they are to be fixed at least 24 hours prior to fixing. Do not place large quantities of material such as chipboard or plasterboard on top of laid flooring as this extreme loading can damage the resilient layers.

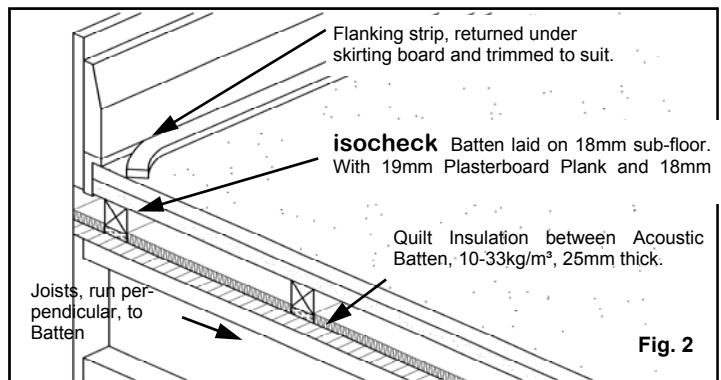
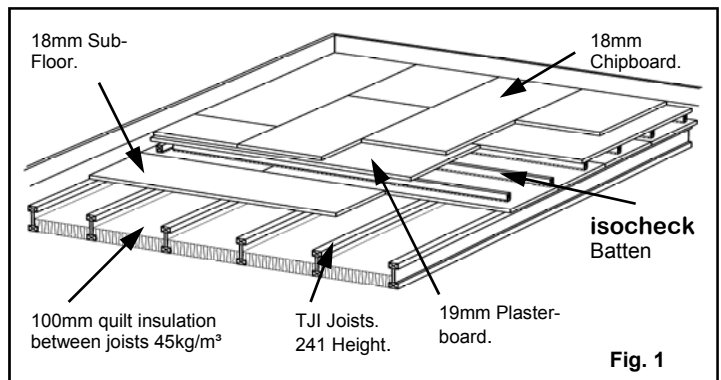

INSTALLATION PROCEDURES

Lay **isocheck** battens around the perimeter of the room approximately 50mm from the wall. **isocheck** Battens should then be laid at 400mm centre's under normal domestic loading. In a timber frame construction load bearing partitions are constructed prior to the installation of the acoustic flooring. Mark the desired location of any non load bearing partitions. Lightweight non-load bearing partitions can be constructed from the timber deck providing all necessary noggins and supports are located before fixing of the timber sub floor. Where lightweight non-load bearing partitions are built from the top of the floating floor a double row of **isocheck** battens should be placed beneath the partitions. Alternatively, if the line of a partition is not supported by a structural joist a supporting ladder frame of battens should be created. The structural performance and location of partitions should be in accordance with the recommendations of the timber kit supplier. All **isocheck** battens must either be laid directly above the main floor joists running in the same direction or be laid perpendicular to the direction of the structural joists and be supported by them. Start each alternate row of **isocheck** battens with a cut length so that joints are staggered leaving gaps at the ends. Where services run across battens – do not notch. Cut battens and place approximately 25mm either side of the pipe. Decrease the batten spacing to between 200 & 300mm apart directly below isolated heavy loads such as bathroom and kitchen furniture and appliances. Place **isocheck** batten across each doorway so as to form a ladder frame to provide extra support. Ensure that a gap is left between the bottom of doorframes and the top of chipboard flooring. Where non load bearing partitions run perpendicular to the structural joist line or run directly above the line of structural joists - place double rows of **isocheck** batten to provide additional support. Alternatively, if the line of a non load bearing partition is not supported by a structural joist a supporting ladder frame of **isocheck** batten should be created. Lay the plaster plank across the **isocheck** battens in a brick-bonded method ensuring that all short edges of plank rest centrally on a batten. Leave a clear 10mm gap at the perimeter. Fix the plank to the bearer using gypsum nails long enough to securely fix the plank but not so long as to bridge the battens resilient layer. The plank should be surface nailed with a minimum of three nails across the face.

Issue: 1

Sheet 1 of 2

Isomass Ltd

St Johns Innovation Centre, Cowley Road,
Cambridge, CB4 0WS

T: 0845 838 33 99

F: 0845 838 33 89

E: technical@isomass.co.uk W: www.isomass.co.uk

The **isocheck** Deep Batten System (for Timber Frame)

LAYING & FIXING INSTRUCTIONS continued

Installation Procedures continued

18mm thick chipboard should be used where bearers are at 400mm centers and normal domestic loading is anticipated. Ensure that the edge joints of the chipboard do not coincide with the edge joints of the plank. Short edges of chipboard should always rest above **isocheck** battens.

Next fix the chipboard using annular ring shank nails or screws, with four fixings across the width of each board. The fixings should be a minimum of 2.5 times the thickness of the board and longer if plank is in use. Care should be taken to ensure that the resilient layer on the bottom of the bearer is not bridged. All tongue and grooved joints must be glued continuously with adhesive on both the top of the tongue and bottom of the groove on each side of the joint. All joints must be tightly butted and excess glue removed with a damp cloth. Ensure that gaps where services come through the flooring are sealed with acoustic sealant to prevent airborne sound leakage. Position the **isocheck** flanking strip in the perimeter gap adjacent to the perimeter wall. The preformed 'L' shape will prevent it from falling down the gap. Fix the skirting board, lightly trapping the strip between the bottom of the skirting board and the flooring. Remove any excess flanking strip with a sharp knife. It is essential to isolate the skirting from the floor to prevent impact sound flanking transmission. The flanking strip should not be removed on completion.

In areas where heavy loadings are anticipated, such as kitchens and bathrooms, the bearer centre's should be reduced to between 200 & 300mm. In cases of extraordinary, loading advice should be sought from the specifier or manufacturer. Isomass Technical Department are available to provide advice where required

Additional Design Recommendations

Access Panels

Providing they are preplanned, the provision of access panels is simple. Panels should be square edged and supported along all edges by **isocheck** battens. Access panels should be screwed down and sealed with acoustic sealant.

Storage Heaters

Storage heaters are considered to be an extraordinary loading and may require support direct from the sub floor, independent of the flooring system. Isomass Technical Department are available to provide advice where required.

Intermediate Expansion Gaps in Flooring

The need for intermediate expansion gaps between sheets of chipboard must be considered where there are uninterrupted runs of flooring more than 5 metres in length. Expansion provision should be calculated at a rate of 2mm per metre run.

PROTECTION

It is advisable to protect the floor surface from any damage by following trades during the remainder of the construction period.

Health and Safety

HANDLING

Acoustic Batten can be awkward to lift. Observe proper lifting methods and if transporting around site, by hand. Care should also be taken to protect hands from splinters during manual handling.

CUTTING

The cutting of Acoustic Batten, either by hand or machine, will produce dust that may be an irritant if inhaled. Use dust masks when carrying out any cutting operations

STORAGE

The foam resilient layer, on Acoustic Batten is manufactured using polyethylene polymers. Therefore, Acoustic Batten should be stored in safe dry areas, laid horizontally and kept away from naked flames. **NO SMOKING** policies must be strictly enforced.

DISPOSAL OF WASTE

In accordance with the Environmental Protection Act 1990 any waste should be disposed of by a licensed waste disposal contractor. Preserved wood may be disposed of in landfills or burned in commercial and industrial incinerators or boilers in accordance with National and Regional regulations.

Issue: 1

Sheet 1 of 2

Isomass Ltd

St Johns Innovation Centre, Cowley Road,
Cambridge, CB4 0WS
T: 0845 838 33 99
F: 0845 838 33 89
E: technical@isomass.co.uk W: www.isomass.co.uk

