

Shallow Batten System

Installation instructions

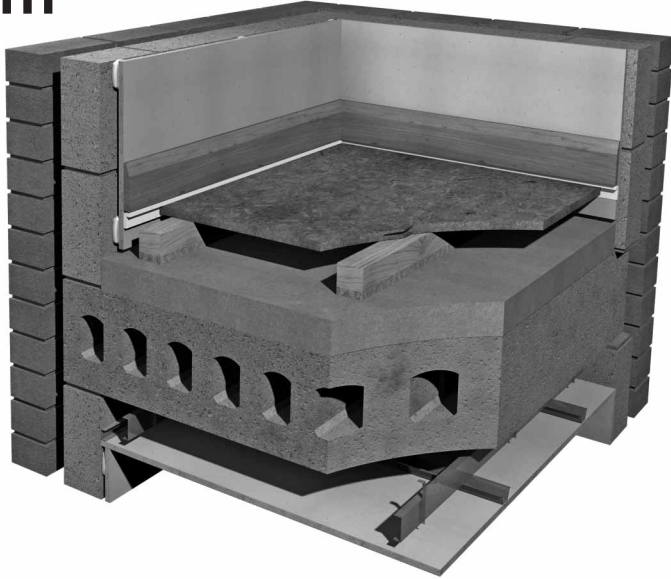

SUSPENDED SYSTEM FOR LEVEL CONCRETE FLOORS

- New build
- Refurbishments
- Conversions
- In conjunction with underfloor heating systems



PRODUCT DATA

Overall size:	1800 x 45 x 50mm 1800 x 45 x 45mm
Resilient layer thickness:	15mm ACF Type 2; 10mm ACF Type 3
Resilient layer:	ACF (Acoustic Chip Foam)



DESCRIPTION

- ❑ The isocheck Shallow Batten system is designed to reduce sound transmission through a concrete structural sub-floor.
- ❑ To be used over level concrete floors for new build projects, refurbishments and conversions.
- ❑ May be installed in conjunction with underfloor heating systems.

- 18mm or 22mm chipboard deck over isocheck 45mm or 50mm Shallow Batten. @ 400mm max. centres.
- $\geq 2400\text{kg/m}^3$ cast in-situ concrete slab with metal frame suspended ceiling with min. 75mm void and 10kg/m^2 plasterboard. **or**
- Bonded screed $\geq 80\text{kg/m}^2$ over min. 150mm hollow core concrete plank (300kg/m^2) with metal frame suspended ceiling with min. 100mm void and 8kg/m^2 plasterboard.

PREPARATION

- ❑ The concrete sub-floor is to be swept free of any loose debris leaving a smooth surface on which to place the isocheck Shallow Batten. The building must be weatherproofed and wet trades dried out before commencing installation of the flooring system. All joints and air paths between concrete units and at perimeter walls must be grouted.
- ❑ Components exposed to wet conditions such as ingress of rain or plumbing leaks should be discarded and replaced. The concrete sub-floor must be level and smooth.
- ❑ The location of services should be detailed at an early stage. Services should be kept at least 150mm away from walls to allow space for perimeter bearers.
- ❑ Risks can be significantly reduced by good detailing and the use of modern flexible adhesives. When laying ceramic tiles on floating floors please contact us for specialist advice.

- ❑ All components should be kept inside, under cover and in dry conditions at all times. Materials should be located in the area in which they are to be fixed at least 24 hours prior to fixing. Do not place large quantities of material such as chipboard or plasterboard on top of laid flooring as this extreme loading can damage the resilient layers.

INSTALLATION

- ❑ Lay Shallow Batten around the perimeter of the room foam side down approximately 50mm from the wall. Shallow Batten should be laid at 400mm centres for 18mm chipboard, or 500mm centres for 22mm chipboard under normal domestic loading.
- ❑ Having laid perimeter Battens infill the remaining area with battens as above. When laying alternate rows of isocheck Shallow Battens, commence with a half-length so that the ends of bearers are staggered. Leave a small gap between Shallow Batten ends. Where services run across bearers – do not notch.

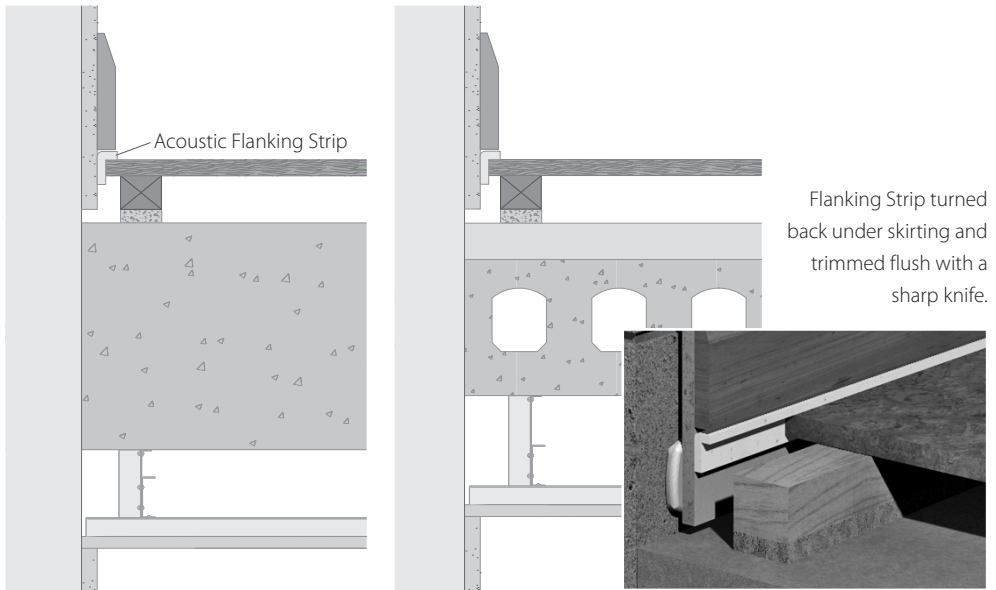

- ❑ Lay Shallow Batten around the perimeter of the room approx. 50mm from the wall. Battens should then be laid at 400mm centre's under normal domestic loading.
- ❑ Cut the Shallow Batten either side of the pipe leaving a 10mm gap. At each threshold a mesh of Shallow Batten should be placed across each doorway to provide extra support.
- ❑ Lay chipboard sheets with long edges across the isocheck battens leaving a 10mm gap at the perimeter. The sheets in adjacent rows must be staggered in a stretcher-bonded fashion. If short edges overhang a batten they must be supported by an additional Shallow Batten.
- ❑ Annular ring or ring shank nails and P.V.A adhesive should be used for fastening the chipboard to Shallow Battens. The nails must be long enough to securely fix the chipboard but not so long as to bridge the foam on the underside of the bearer. Adhesive should be applied to the Batten prior to laying each sheet of chipboard.
- ❑ All tongue and grooved joints must be continuously glued with adhesive both on the top of the tongue and the bottom of the groove otherwise any movement will lead to squeaking. Spot gluing is NOT sufficient (to prevent squeaking). All joints must be tightly butted and excess glue removed with a damp cloth. Finally the boards should be surface nailed / screwed with a minimum of four nails or screws across the width of each sheet, two about 25mm from each end and two equidistant between.
- ❑ Ensure that gaps where services come through the flooring are sealed with acoustic sealant to prevent airborne sound leakage.
- ❑ The need for intermediate expansion gaps between sheets of chipboard must be considered where there are uninterrupted runs of flooring more than 5 metres in length. Expansion provision should be calculated at a rate of 2mm per metre run and the gap filled with acoustic sealant.

- ❑ Position the isocheck Flanking Strip in the perimeter gap adjacent to the perimeter wall. The preformed 'L' shape will prevent it from falling down the gap.
- ❑ Fix the skirting board, lightly trapping the strip between the bottom of the skirting board and the flooring.
- ❑ Remove any excess Flanking Strip with a sharp knife. It is essential to isolate the skirting from the floor to prevent impact sound flanking transmission.

ADDITIONAL SUPPORT

- ❑ Where the edge of the flooring boards fall between a line of battens, or where there are concentrated loads such as baths, additional sections of Shallow Batten are required. For joints in the boards place a section of acoustic batten under the joint to support adjacent floorboards and fix as normal.

PROTECTION

- ❑ It is advisable to protect the floor surface from any damage by following trades during the remainder of the construction period.

DESIGN RECOMMENDATIONS

- ❑ Partitions should normally be erected from the sub-floor and not on top of the floating floor. Where lightweight timber or metal stud non load bearing partitions are built from the top of the floating floor a double row of Shallow Battens should be placed beneath the partitions. All inspection panels should be square and supported along all edges by isocheck Shallow Battens. Access panels should be screwed down.
- ❑ In areas where heavy loadings are anticipated, such as kitchens and bathrooms, the bearer centre's should be reduced to between 200 & 300mm. In cases of extraordinary, loading advice should be sought from the specifier or manufacturer. Isomass's Technical Department are available to provide advice where required.

If in doubt on any area, please call Isomass prior to commencement of work.

Every effort has been taken in the preparation of this sheet to ensure the accuracy of representations contained herein. Recommendations as to the use of materials, construction details and methods of installation are given in good faith and relate to typical situations. However, every site has different characteristics and reliance should not be placed upon the foregoing recommendations. Advice can be given as to specific applications of the products, upon request to isomass building products.



Units 10 & 11, Avenue Business Park, Off Brockley Road,
Elsworth, Cambridgeshire CB23 4EY

Tel: 0845 838 33 99 • Fax: 0845 838 33 89 • Email: info@isomass.co.uk • www.isomass.co.uk